

ATRIUM LINEO 14 elem.

balustrada QUATRO



ATRIUM®

www.atriumsystem.eu
+48 32 609 00 00
www.facebook.com/atriumsystem

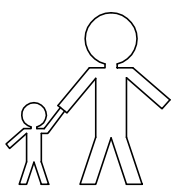
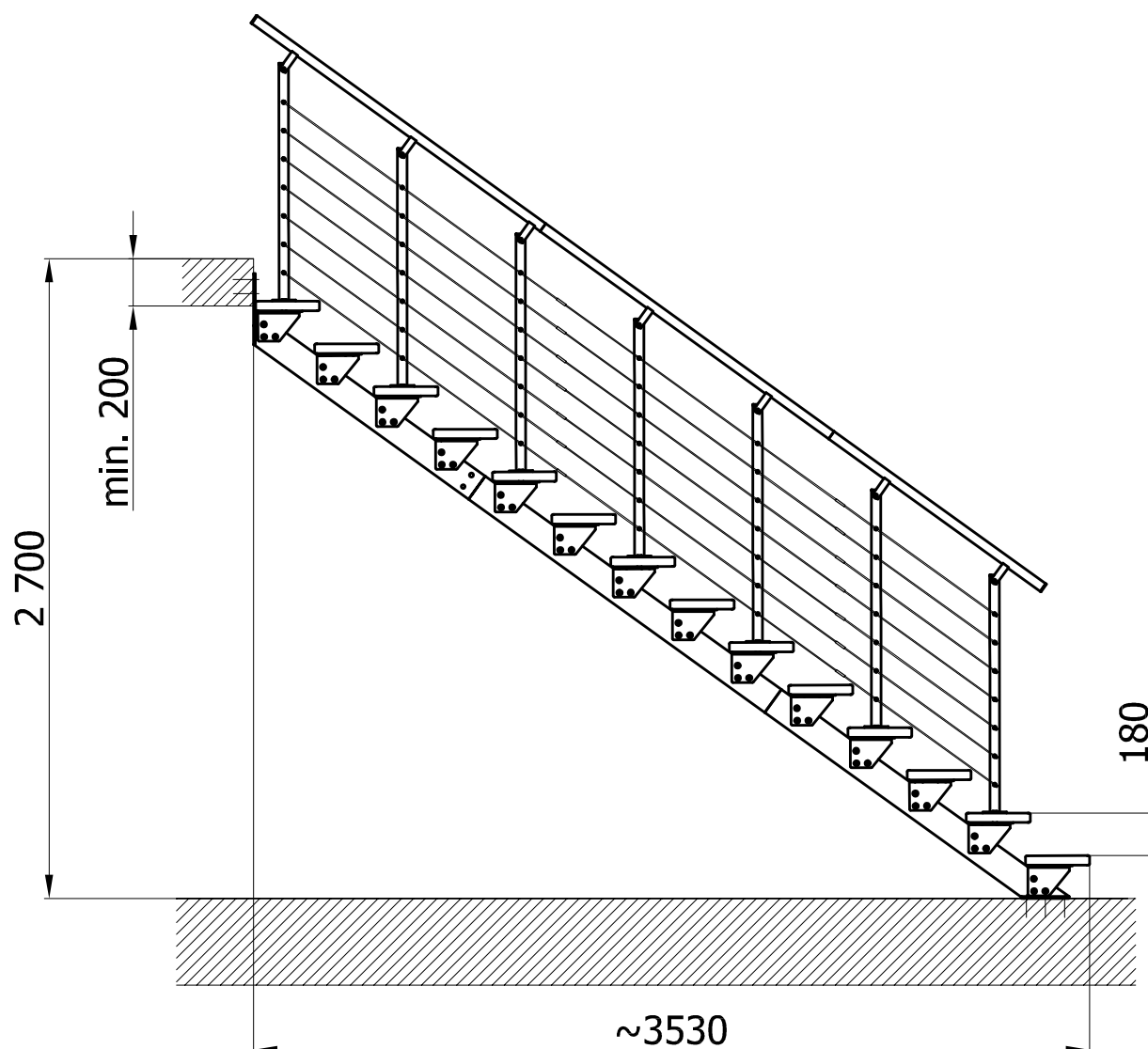
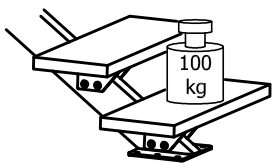
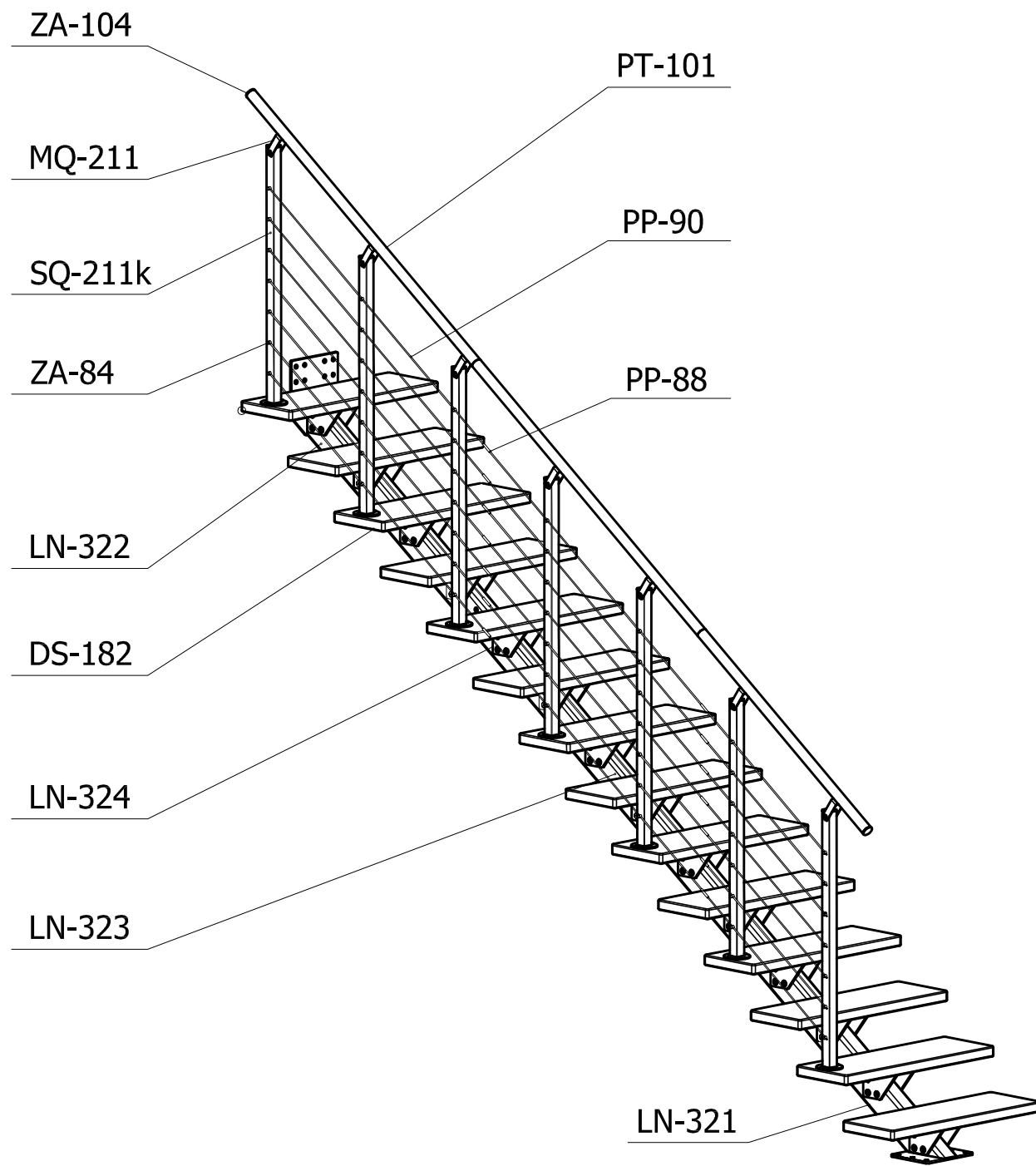

OK!

wykaz części/detail list/Stückliste

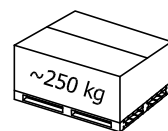

<p>a</p> <p>LN-322</p>	<p>b</p> <p>LN-323</p>	<p>c</p> <p>LN-321</p>	<p>d</p> <p>LN-324</p>
<p>e</p> <p>DS-182</p>	<p>f</p> <p>SQ-211k</p>	<p>g</p> <p>MQ-211</p>	<p>h</p> <p>ZA-235</p>
<p>i</p> <p>φ40 (φ50)</p> <p>PT-101</p>	<p>j</p> <p>φ5</p> <p>PP-90</p>	<p>k</p> <p>PP-88</p>	<p>l</p> <p>ZA-84</p>
<p>m</p> <p>M8x40</p>	<p>n1 M6</p> <p>n2 M8</p> <p>n3 M10</p>	<p>o1 M6 L=34</p> <p>o2 M10 L=85</p>	<p>p</p> <p>M4x35</p>
<p>r</p> <p>WD-144 6x35</p>	<p>s</p> <p>3,9x19</p>	<p>t</p> <p>ZA-104</p>	<p>S4+S5+S6</p>

Instrukcja pokazuje typowy komplet ATRIUM LINEO
dla nietypowego kompletu skład może odbiegać od pokazanego w instrukcji

The instruction shows the typical set of ATRIUM LINEO
For atypical set the composition may differ from the one shown in the instruction

Die Instruktion zeigt den typischen Satz von ATRIUM LINEO
Bei einem nicht typischen Satz kann die Zusammensetzung von der im Instruktion

potrzebne do montażu:

needed to assembly:

für die Montage notwendig:

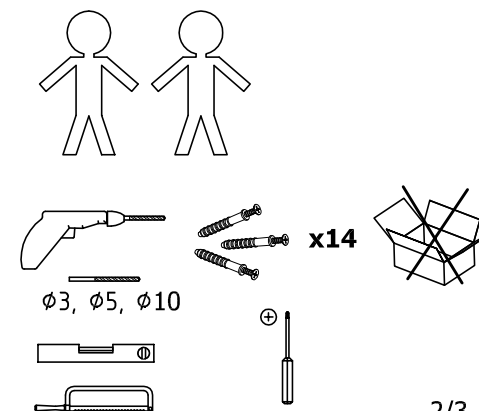

$hst = H / (n + 1)$
 $n = 14 \quad hst = 18 \text{ cm}$
 (typowy zestaw)
 (typical set)

